

## SPXTIN2005-01: Floor Adapter

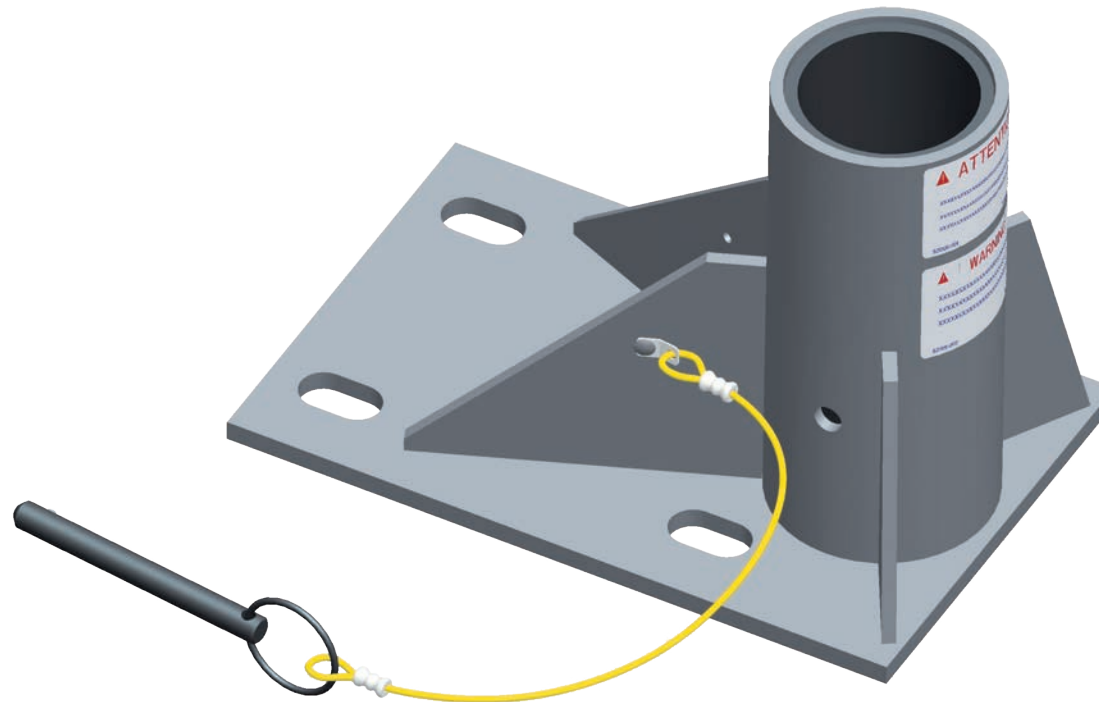

### SpanSet Australia Ltd

13 Pullman Place  
Emu Plains  
NSW 2750  
Australia

### Telephone

+61 2 4735 3955

### Fax

+61 2 4735 3630

### E-mail

[sales@spanset.com.au](mailto:sales@spanset.com.au)

### Internet

[www.spanset.com.au](http://www.spanset.com.au)

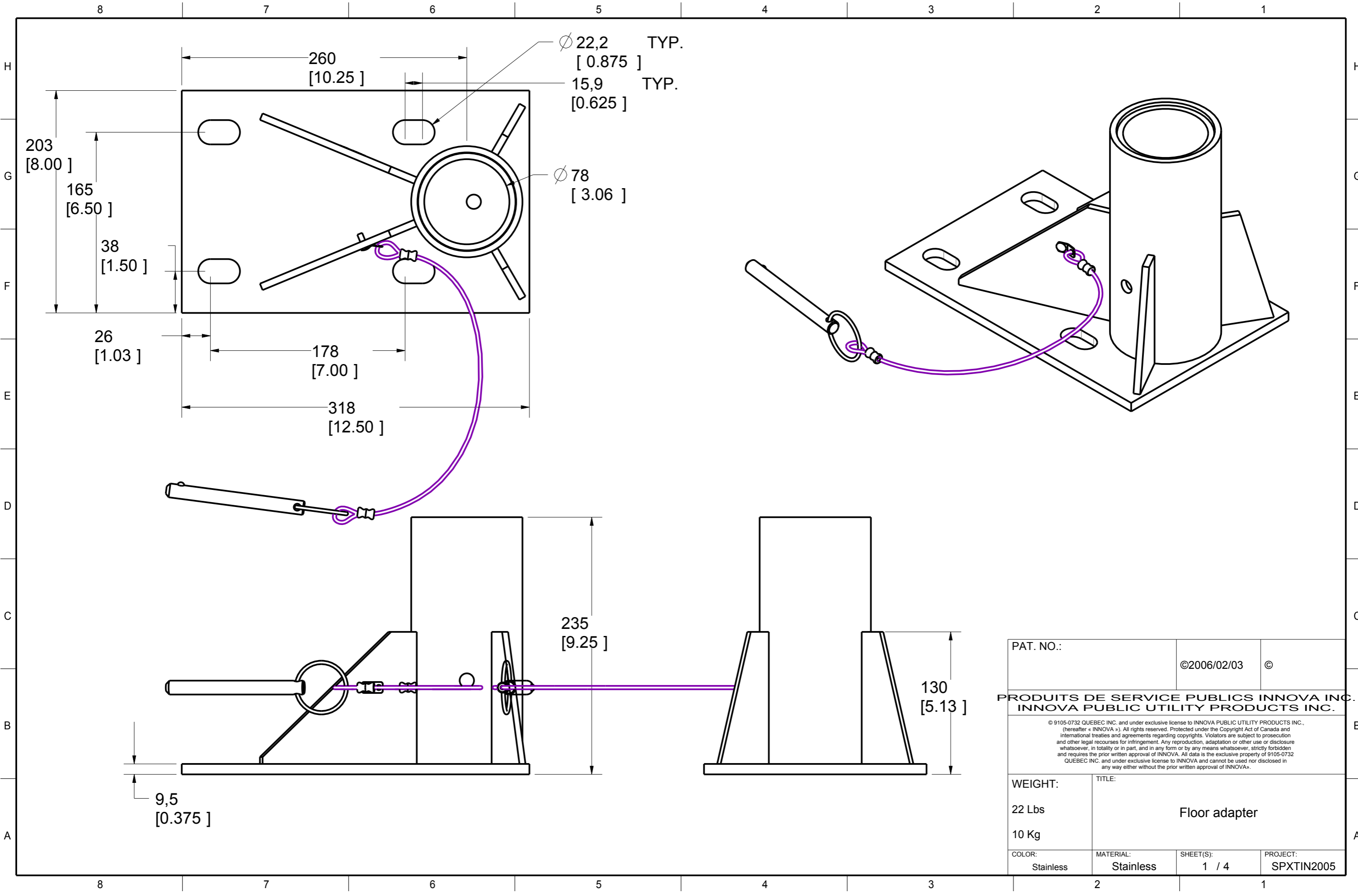

$\varnothing$  22,2 TYP.  
 [ 0.875 ]  
 15,9 TYP.  
 [ 0.625 ]

$\varnothing$  78  
 [ 3.06 ]

235  
 [ 9.25 ]

130  
 [ 5.13 ]

PAT. NO.:		©2006/02/03		©
<b>PRODUITS DE SERVICE PUBLICS INNOVA INC.</b> <b>INNOVA PUBLIC UTILITY PRODUCTS INC.</b>				
<small>© 9105-0732 QUEBEC INC. and under exclusive license to INNOVA PUBLIC UTILITY PRODUCTS INC., (hereafter « INNOVA »). All rights reserved. Protected under the Copyright Act of Canada and international treaties and agreements regarding copyrights. Violators are subject to prosecution and other legal recourses for infringement. Any reproduction, adaptation or other use or disclosure whatsoever, in totality or in part, and in any form or by any means whatsoever, strictly forbidden and requires the prior written approval of INNOVA. All data is the exclusive property of 9105-0732 QUEBEC INC. and under exclusive license to INNOVA and cannot be used nor disclosed in any way either without the prior written approval of INNOVA.</small>				
WEIGHT:		TITLE:		
22 Lbs		Floor adapter		
10 Kg				
COLOR:	MATERIAL:	SHEET(S):	PROJECT:	
Stainless	Stainless	1 / 4	SPXTIN2005	

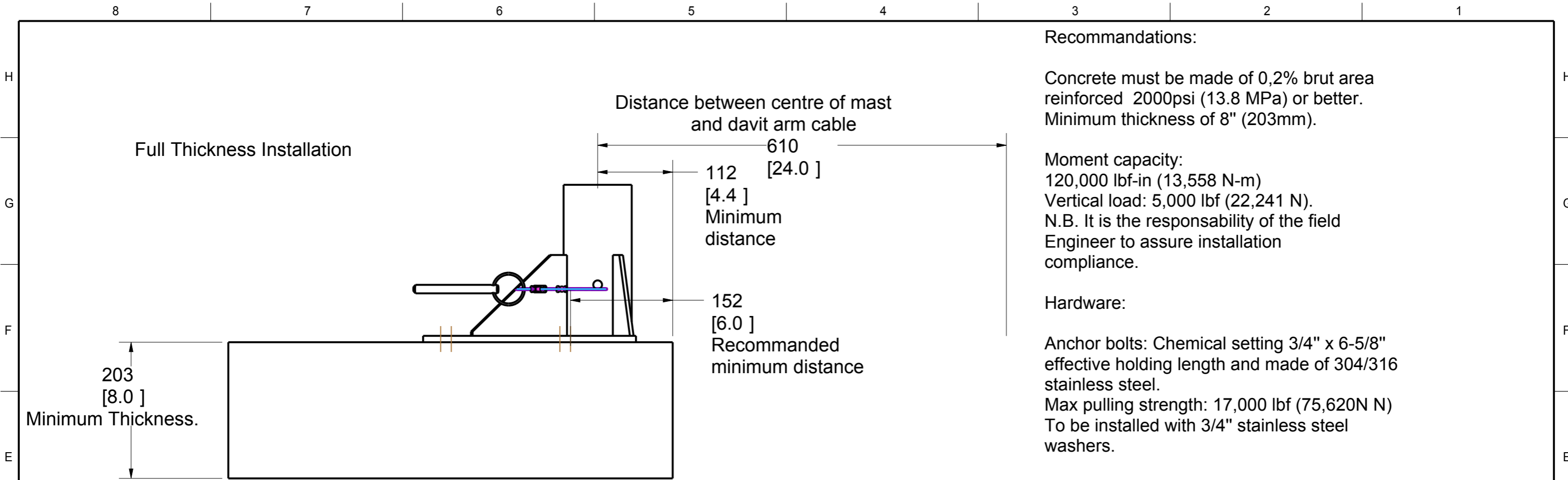

**Recommandations:**

Concrete must be made of 0,2% brut area reinforced 2000psi (13.8 MPa) or better.  
Minimum thickness of 8" (203mm).

**Moment capacity:**  
120,000 lbf-in (13,558 N-m)  
Vertical load: 5,000 lbf (22,241 N).  
N.B. It is the responsibility of the field Engineer to assure installation compliance.

**Hardware:**

Anchor bolts: Chemical setting 3/4" x 6-5/8" effective holding length and made of 304/316 stainless steel.  
Max pulling strength: 17,000 lbf (75,620N N)  
To be installed with 3/4" stainless steel washers.

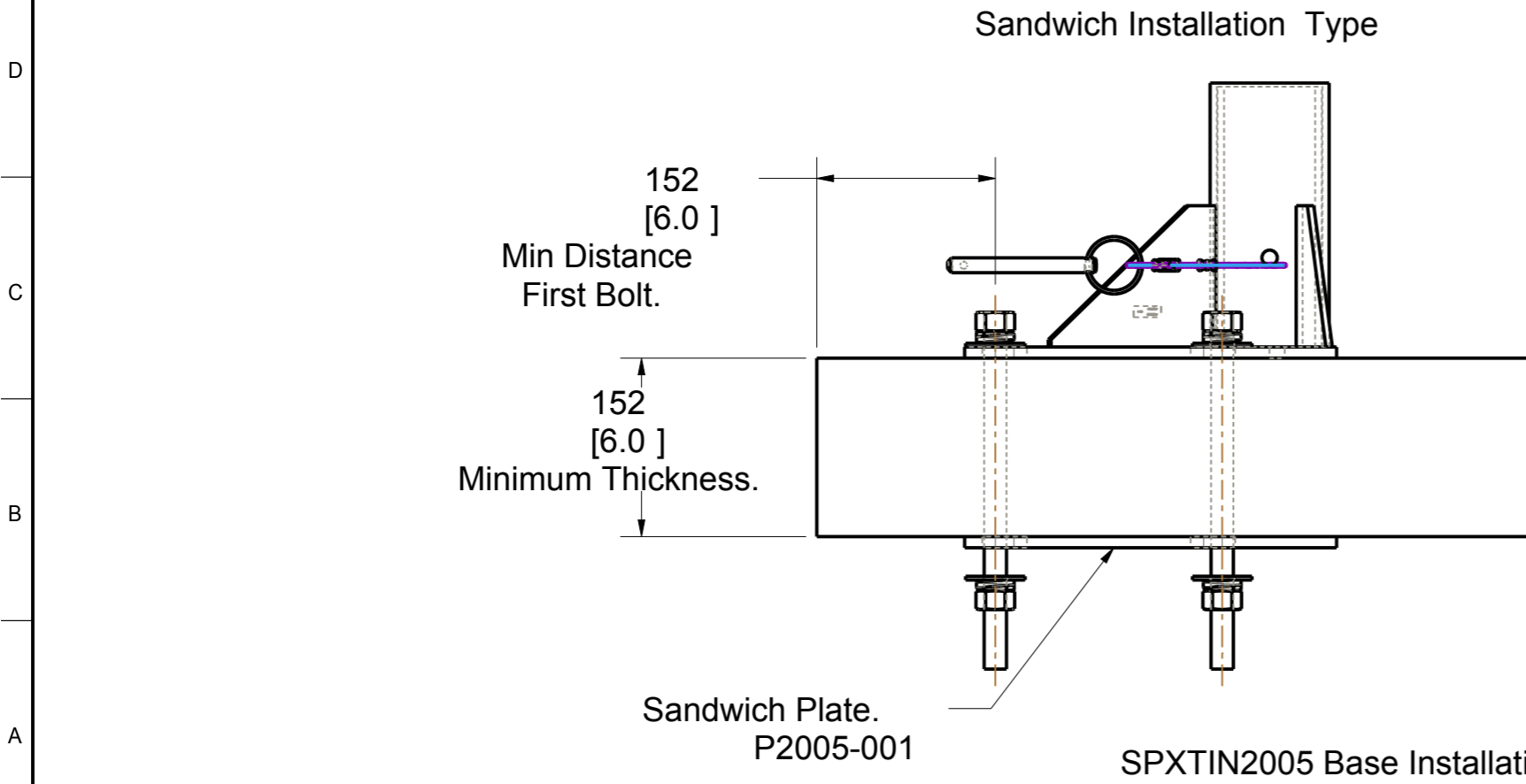

SPXTIN2005 Base Installation Requirements

PAT. NO.:		©2006/02/03	©
<b>PRODUITS DE SERVICE PUBLICS INNOVA INC.</b> <b>INNOVA PUBLIC UTILITY PRODUCTS INC.</b>			
<small>© 9105-0732 QUEBEC INC. and under exclusive license to INNOVA PUBLIC UTILITY PRODUCTS INC., (hereafter « INNOVA »). All rights reserved. Protected under the Copyright Act of Canada and international treaties and agreements regarding copyrights. Violators are subject to prosecution and other legal recourses for infringement. Any reproduction, adaptation or other use or disclosure whatsoever, in totality or in part, and in any form or by any means whatsoever, strictly forbidden and requires the prior written approval of INNOVA. All data is the exclusive property of 9105-0732 QUEBEC INC. and under exclusive license to INNOVA and cannot be used nor disclosed in any way either without the prior written approval of INNOVA».</small>			
WEIGHT:	TITLE:		
22 Lbs	Floor adapter		
10 Kg			
COLOR:	MATERIAL:	SHEET(S):	PROJECT:
Stainless	Stainless	2 / 4	SPXTIN2005

**SPECIFICATIONS**

This product is man rated with a maximum working capacity of 360lbs (164kg). It is only to be used in conjunction with personal fall arrest equipment that limits the maximum arrest force (MAF).

Maximum Working Moment : 976 N-m (8,640 lbf-in)  
 Maximum Moment : 13,558 N-m (120,000 lbf-in)

**STANDARDS**

Meets the following standards:  
 OSHA Personal fall arrest system - 1910.66 App C  
 ANSI Safety requirements for personal fall arrest system, subsystems and components Z359.1 ( R1999 ) / 2007  
 CAN/CSA Fall arresters, vertical lifelines, and rails Z259.2.1-98

**MATERIAL AND CONSTRUCTION**

Plate, gussets and sleeve : 304 Stainless Steel  
 Sleeve bearing : PVC Pipe.  
 Pin : Stainless Steel  
 Lanyard : Nylon covered Steel Cable  
 Welding Certification : CSA W59 & W47.1,AWS D1.6

**RESTRICTIONS**

**IMPORTANT :**

The positioning pin must always be in place when manouvering personnel. Adaptors are designed to function only with Innova public utility products INC. equipment. Anchorage hardware must be installed by qualified and experienced personnel. The installer must follow the anchorage hardware manufacturers recommendations at all time. Periodic inspections of hardware must be done. All equipment and hardware must be inspected before re-using by qualified personnel when a fall has occurred.

Product number : SPXTIN2005

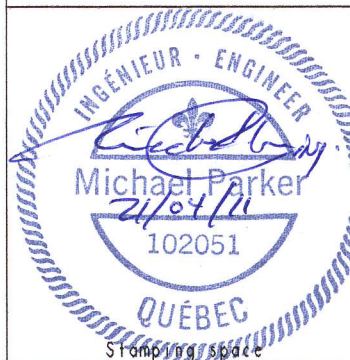
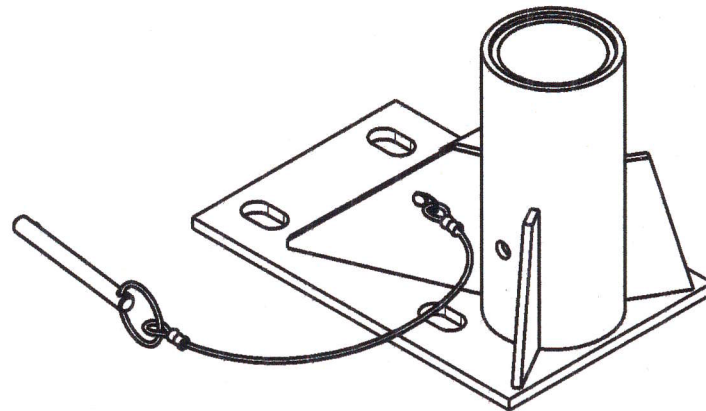

PAT. NO.:	©2006/02/03	©
-----------	-------------	---

**PRODUITS DE SERVICE PUBLICS INNOVA INC.  
 INNOVA PUBLIC UTILITY PRODUCTS INC.**

© 0105-0732 QUEBEC INC. and under exclusive license to INNOVA PUBLIC UTILITY PRODUCTS INC., hereinafter "INNOVA". All rights reserved. Protected under the Copyright Act of Canada and international treaties and agreements regarding copyrights. Violators are subject to prosecution and other legal recourse for infringement. Any reproduction, adaptation or other use of disclosure whatsoever, in entirety or in part, and in any form or by any means whatsoever, strictly forbidden and requires the prior written approval of INNOVA. All data is the exclusive property of 0105-0732 QUEBEC INC. and under exclusive license to INNOVA and cannot be used nor disclosed in any way either without the prior written approval of INNOVA.

WEIGHT:	TITLE:		
22 Lbs	Floor adapter		
10 Kg			
COLOR:	MATERIAL:	SHEET(S):	PROJECT:
	Stainless Steel	3 / 4	SPXTIN2005

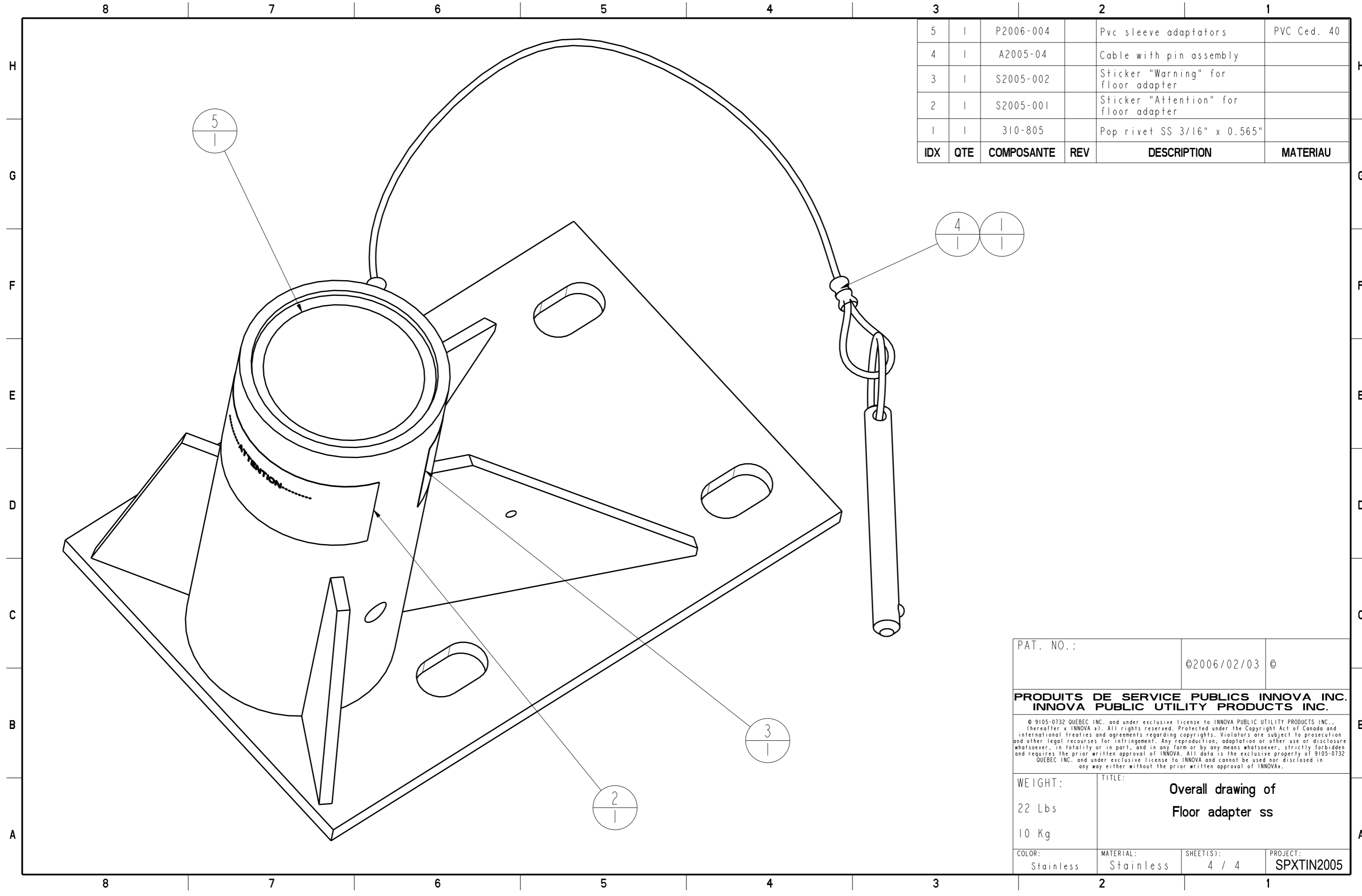

5	1	P2006-004		Pvc sleeve adaptators	PVC Ced. 40
4	1	A2005-04		Cable with pin assembly	
3	1	S2005-002		Sticker "Warning" for floor adapter	
2	1	S2005-001		Sticker "Attention" for floor adapter	
1	1	310-805		Pop rivet SS 3/16" x 0.565"	
IDX	QTE	COMPOSANTE	REV	DESCRIPTION	MATERIAU

PAT. NO.:		©2006/02/03 ©	
<b>PRODUITS DE SERVICE PUBLICS INNOVA INC. INNOVA PUBLIC UTILITY PRODUCTS INC.</b>			
<small>© 9105-0732 QUEBEC INC. and under exclusive license to INNOVA PUBLIC UTILITY PRODUCTS INC., (hereafter « INNOVA »). All rights reserved. Protected under the Copyright Act of Canada and international treaties and agreements regarding copyrights. Violators are subject to prosecution and other legal recourses for infringement. Any reproduction, adaptation or other use or disclosure whatsoever, in totality or in part, and in any form or by any means whatsoever, strictly forbidden and requires the prior written approval of INNOVA. All data is the exclusive property of 9105-0732 QUEBEC INC. and under exclusive license to INNOVA and cannot be used nor disclosed in any way either without the prior written approval of INNOVA.</small>			
WEIGHT:	TITLE:		
22 Lbs	<b>Overall drawing of Floor adapter ss</b>		
10 Kg	COLOR:	MATERIAL:	SHEET(S):
	Stainless	Stainless	4 / 4
			PROJECT:
			SPXTIN2005