

## SPXTIN2109-01: 18" Mast Extension



### SpanSet Australia Ltd

150 Old Bathurst Road  
Emu Plains  
NSW 2750  
Australia

#### Telephone

+61 2 4735 3955

#### Fax

+61 2 4735 3630

#### E-mail

[sales@spanset.com.au](mailto:sales@spanset.com.au)

#### Internet

[www.spanset.com.au](http://www.spanset.com.au)

Product number: SPXTIN2109

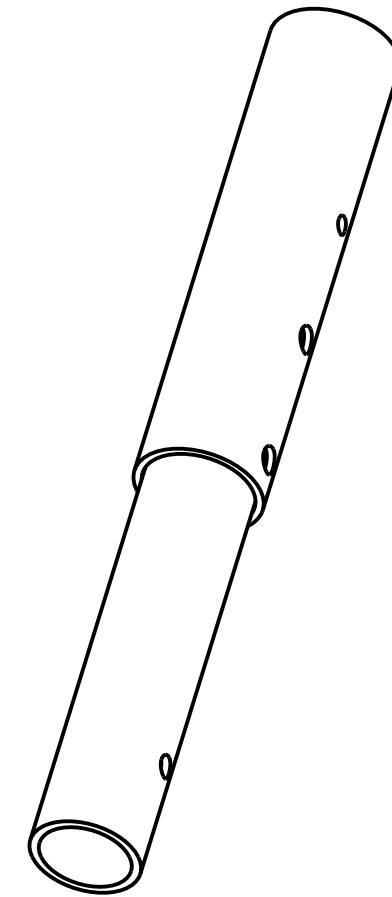
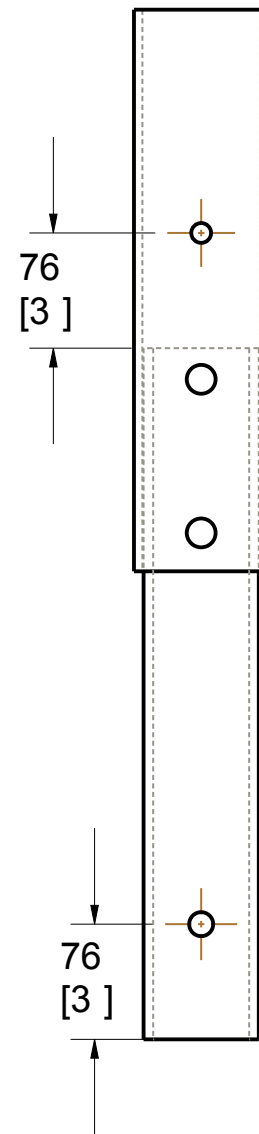
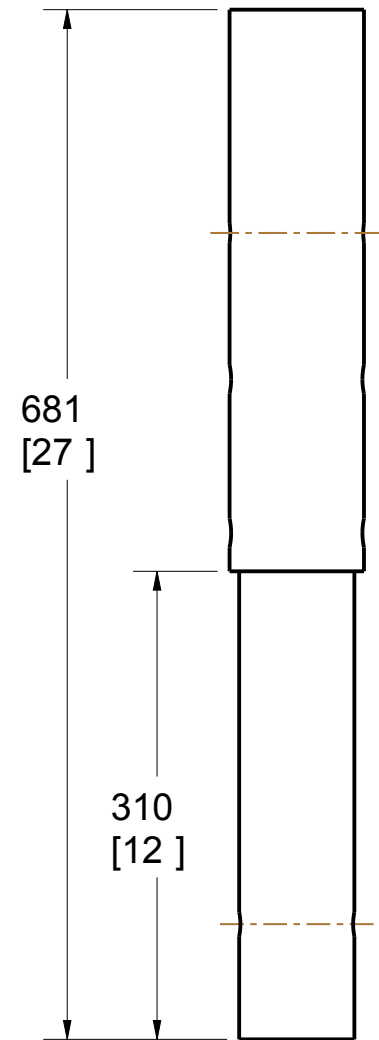
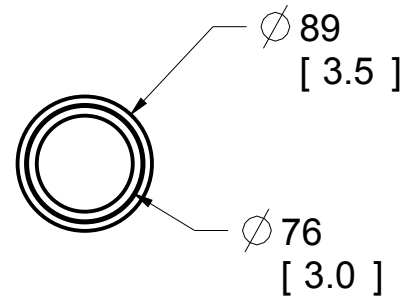

PAT. NO.:		©17/08/2010	©
<b>PRODUITS DE SERVICE PUBLICS INNOVA INC.</b> <b>INNOVA PUBLIC UTILITY PRODUCTS INC.</b>			
<small>© 9105-0732 QUEBEC INC. and under exclusive license to INNOVA PUBLIC UTILITY PRODUCTS INC., (hereafter « INNOVA »). All rights reserved. Protected under the Copyright Act of Canada and international treaties and agreements regarding copyrights. Violators are subject to prosecution and other legal recourses for infringement. Any reproduction, adaptation or other use or disclosure whatsoever, in totality or in part, and in any form or by any means whatsoever, strictly forbidden and requires the prior written approval of INNOVA. All data is the exclusive property of 9105-0732 QUEBEC INC. and under exclusive license to INNOVA and cannot be used nor disclosed in any way either without the prior written approval of INNOVA.</small>			
WEIGHT:	TITLE:		
24 Lbs	18" mast extension		
11 Kg			
COLOR:	MATERIAL:	SHEET(S):	PROJECT:
Yellow security	Steel	1 / 4	SPXTIN2109

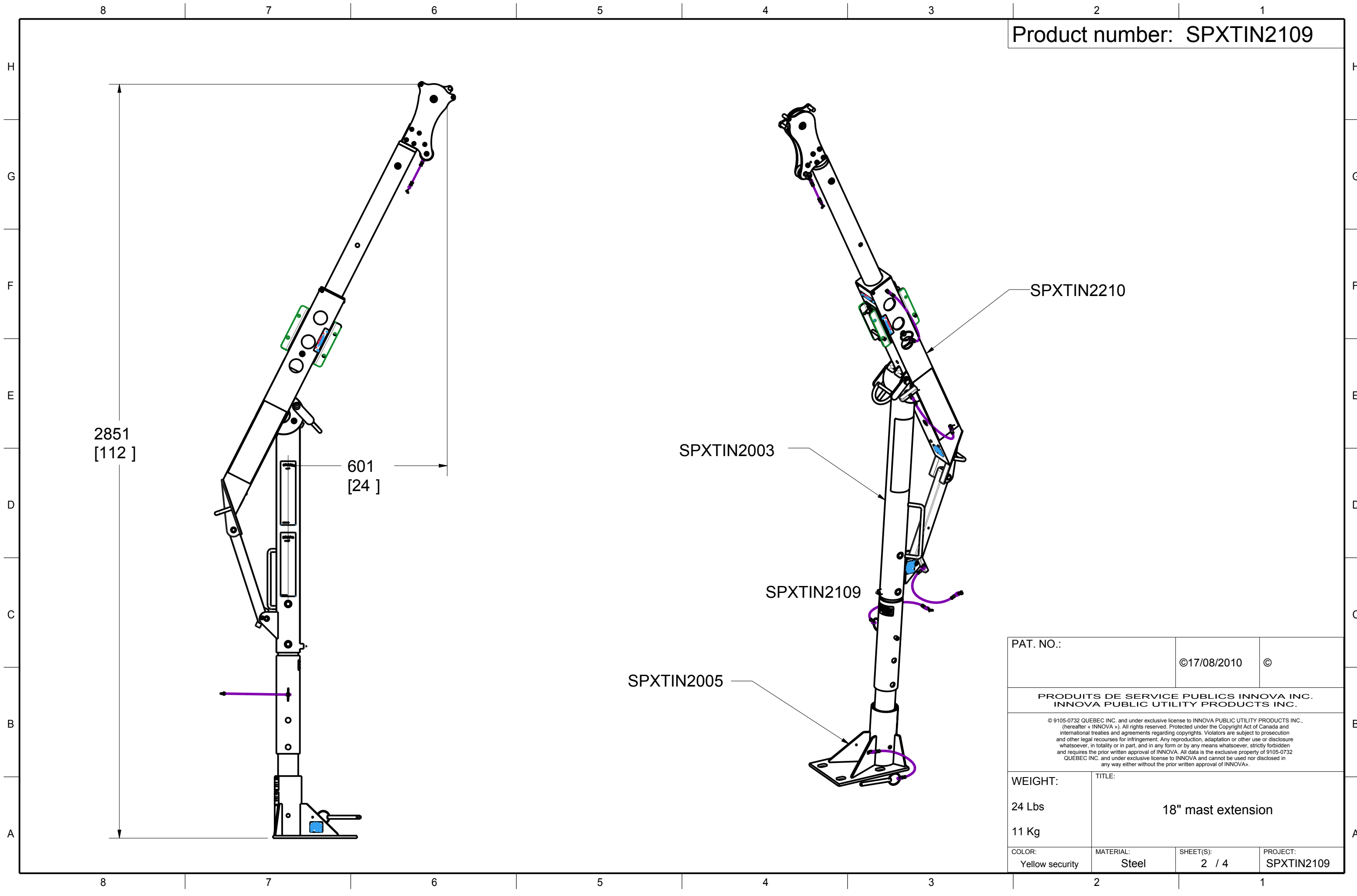

PAT. NO.:		©17/08/2010	©
<b>PRODUITS DE SERVICE PUBLICS INNOVA INC.</b> <b>INNOVA PUBLIC UTILITY PRODUCTS INC.</b>			
© 9105-0732 QUEBEC INC. and under exclusive license to INNOVA PUBLIC UTILITY PRODUCTS INC. (hereafter « INNOVA »). All rights reserved. Protected under the Copyright Act of Canada and international treaties and agreements regarding copyrights. Violators are subject to prosecution and other legal recourses for infringement. Any reproduction, adaptation or other use or disclosure whatsoever, in totality or in part, and in any form or by any means whatsoever, strictly forbidden and requires the prior written approval of INNOVA. All data is the exclusive property of 9105-0732 QUEBEC INC. and under exclusive license to INNOVA and cannot be used nor disclosed in any way either without the prior written approval of INNOVA.			
WEIGHT:	TITLE:		
24 Lbs	18" mast extension		
11 Kg			
COLOR:	MATERIAL:	SHEET(S):	PROJECT:
Yellow security	Steel	2 / 4	SPXTIN2109

SPECIFICATIONS

Working load (mass):  
 With Davit Arm SPXTIN2002 or SPXTIN2210 and mast SPXTIN2003 : 164 kg (360 lbs)

Max capacity without deformation:  
 With Davit Arm SPXTIN2002 or SPXTIN2210 and mast SPXTIN2003 : 16298 N (3664 lbf)  
 Maximum Moment : 9935 N-m (87,936 lbf-in)

STANDARDS

Meets the following standards:  
 OSHA Personal fall arrest system - 1910.66 App C  
 ANSI Safety requirements for personal fall arrest system,  
 subsystems and components Z359.1 ( R1999 )  
 CAN/CSA Fall arresters, vertical lifelines, and rails Z259.2.1-98

MATERIAL AND CONSTRUCTION

Cylindre and sleeve : Steel DOM 1026  
 Pin : Zinc plated Steel  
 Lanyard : Nylon covered Steel Cable  
 Welding Certification : CSA W59 & W47.1, AWS D1.6

RESTRICTIONS

This product is to be used only with products approved by Innova utility products INC.

Important:

This product is man rated and shall be used in conjunction with Fall Arrest Equipment which limits the maximum arrest force (MAF).

Product number : SPXTIN2109

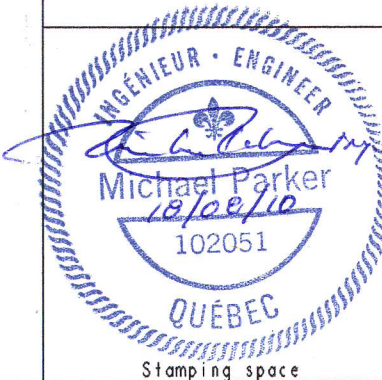
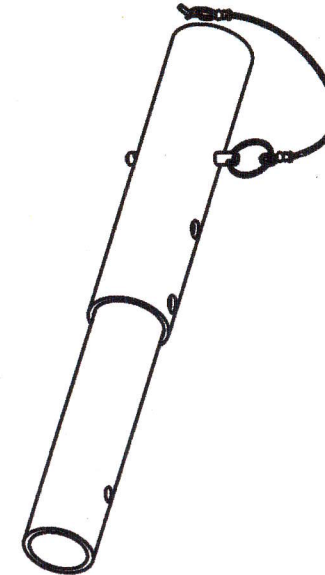

PAT. NO.:		017/08/2010	0
PRODUITS DE SERVICE PUBLICS INNOVA INC. INNOVA PUBLIC UTILITY PRODUCTS INC.			
<small>© 8185-9732 QUEBEC INC. and under exclusive license to INNOVA PUBLIC UTILITY PRODUCTS INC., (hereafter "INNOVA"). All rights reserved. Protected under the Copyright Act of Canada and international treaties and agreements regarding copyrights. Violators are subject to prosecution and other legal recourse for infringement. Any reproduction, adaptation or other use or disclosure whatsoever, in totality or in part, and in any form or by any means whatsoever, strictly forbidden and requires the prior written approval of INNOVA. All data is the exclusive property of 8185-9732 QUEBEC INC. and under exclusive license to INNOVA and cannot be used nor disclosed in any way either without the prior written approval of INNOVA.</small>			
WEIGHT:	TITLE:		
24 Lbs	18" mast extension		
11 Kg			
COLOR:	MATERIAL:	SHEET(S):	PROJECT:
Yellow security	Steel	3 / 4	SPXTIN2109

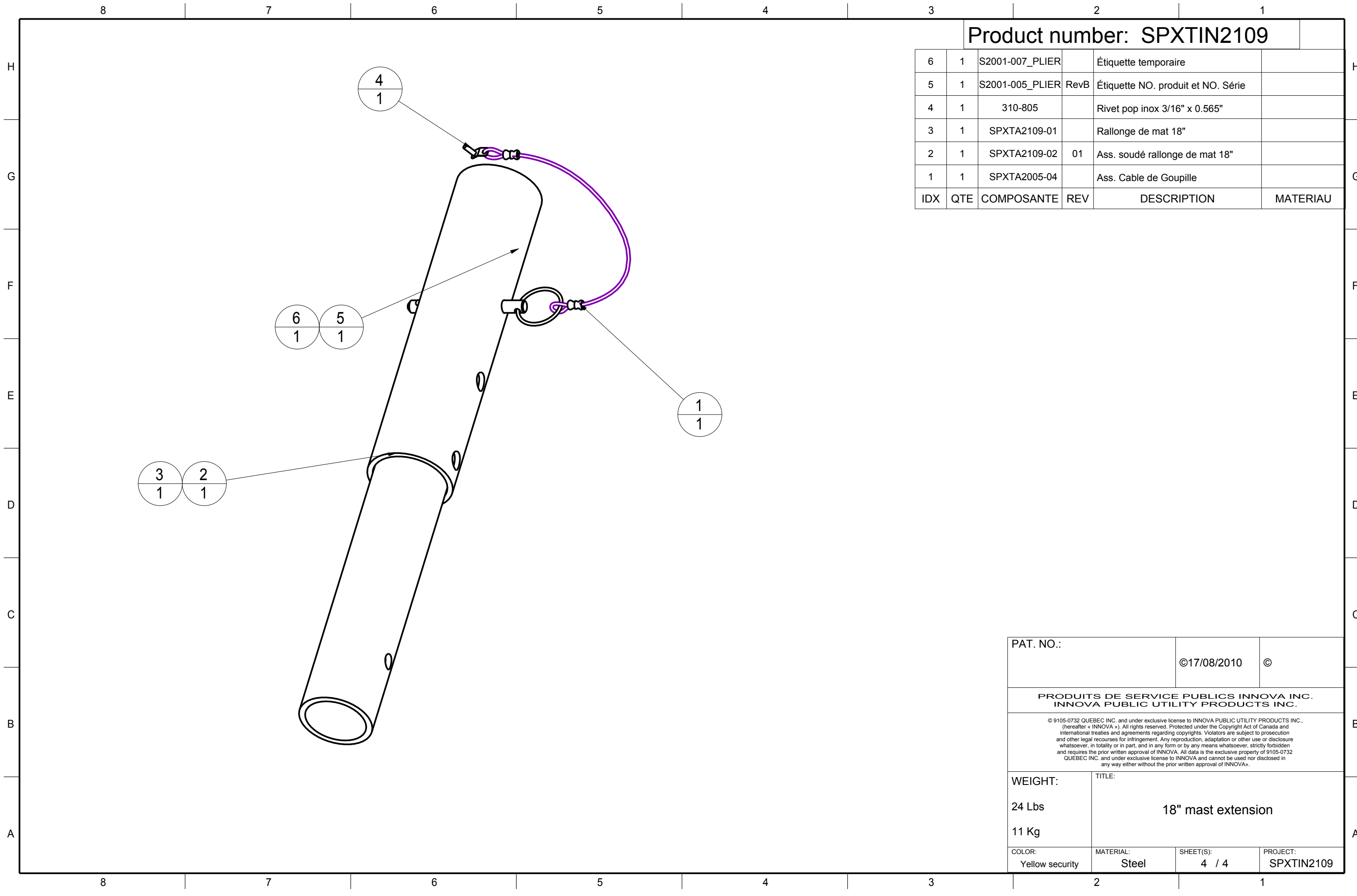

Product number: SPXTIN2109

IDX	QTE	COMPOSANTE	REV	DESCRIPTION	MATERIAU
6	1	S2001-007_PLIER		Étiquette temporaire	
5	1	S2001-005_PLIER	RevB	Étiquette NO. produit et NO. Série	
4	1	310-805		Rivet pop inox 3/16" x 0.565"	
3	1	SPXTA2109-01		Rallonge de mat 18"	
2	1	SPXTA2109-02	01	Ass. soudé rallonge de mat 18"	
1	1	SPXTA2005-04		Ass. Cable de Goupille	

PAT. NO.:		©17/08/2010	©
<b>PRODUITS DE SERVICE PUBLICS INNOVA INC.</b> <b>INNOVA PUBLIC UTILITY PRODUCTS INC.</b>			
© 9105-0732 QUEBEC INC. and under exclusive license to INNOVA PUBLIC UTILITY PRODUCTS INC., (hereafter « INNOVA »). All rights reserved. Protected under the Copyright Act of Canada and international treaties and agreements regarding copyrights. Violators are subject to prosecution and other legal recourses for infringement. Any reproduction, adaptation or other use or disclosure whatsoever, in totality or in part, and in any form or by any means whatsoever, strictly forbidden and requires the prior written approval of INNOVA. All data is the exclusive property of 9105-0732 QUEBEC INC. and under exclusive license to INNOVA and cannot be used nor disclosed in any way either without the prior written approval of INNOVA.			
WEIGHT:	TITLE:		
24 Lbs	18" mast extension		
11 Kg			
COLOR:	MATERIAL:	SHEET(S):	PROJECT:
Yellow security	Steel	4 / 4	SPXTIN2109