

SPXTIN2222-01: Manhole Entry Ring System for Hole 26" to 28"

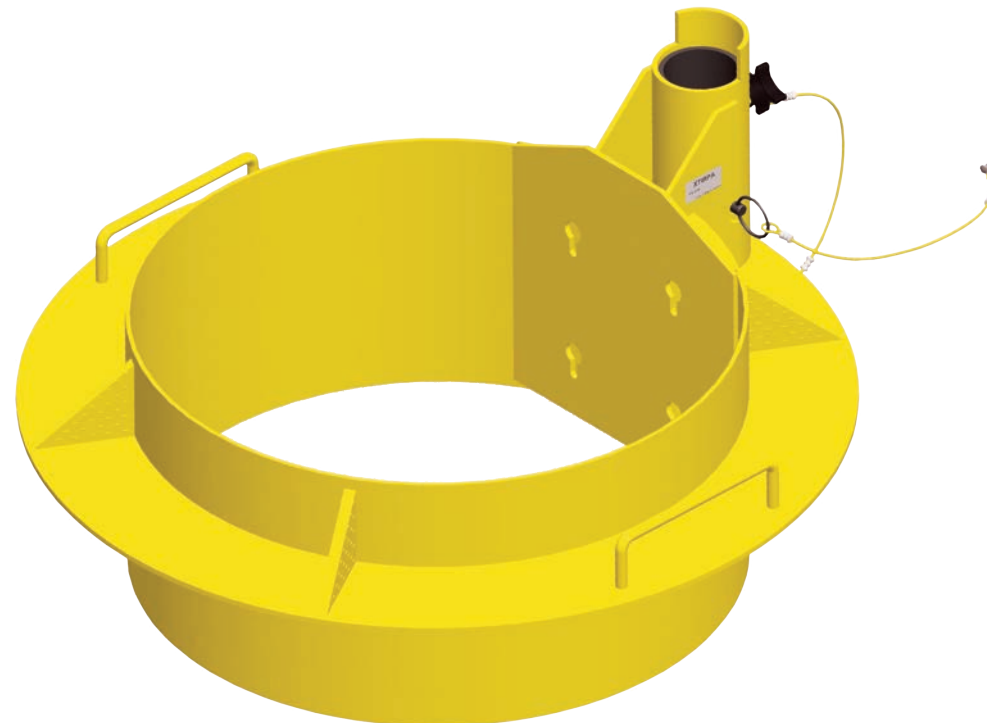

SpanSet Australia Ltd

13 Pullman Place
Emu Plains
NSW 2750
Australia

Telephone

+61 2 4735 3955

Fax

+61 2 4735 3630

E-mail

sales@spanset.com.au

Internet

www.spanset.com.au

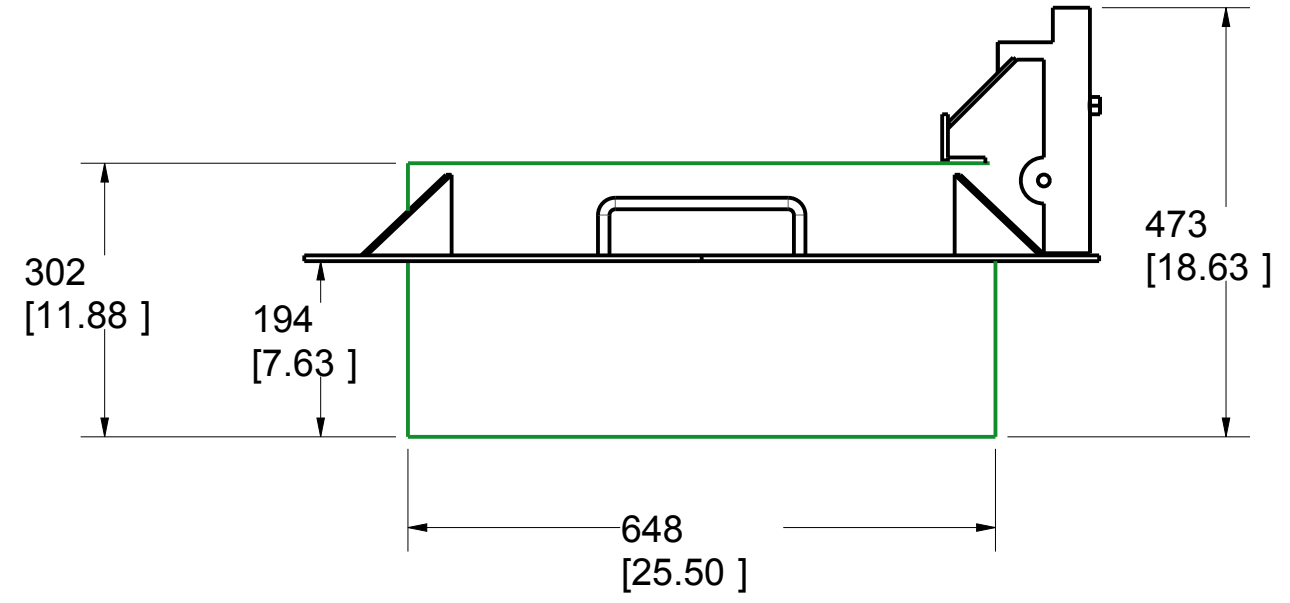
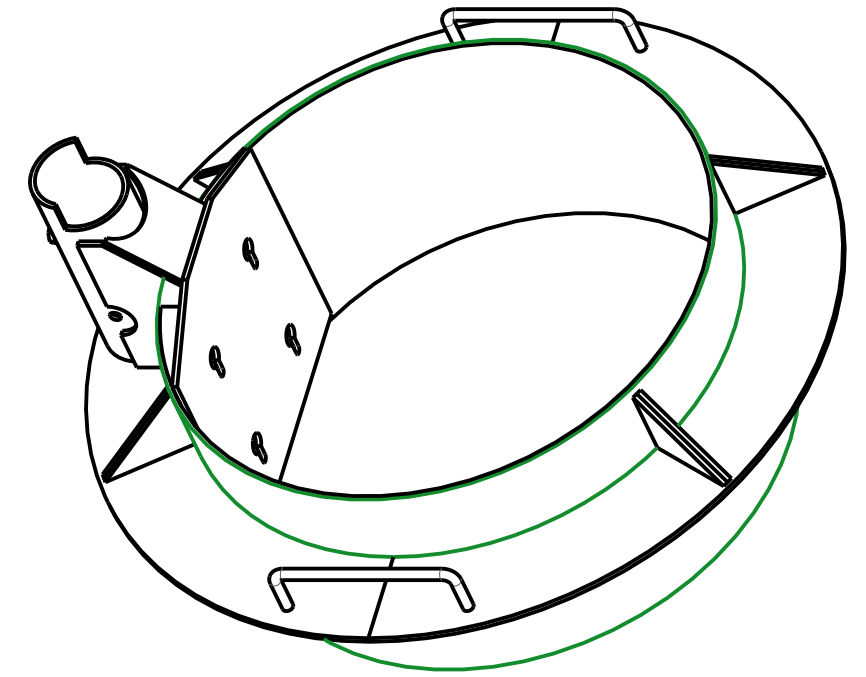
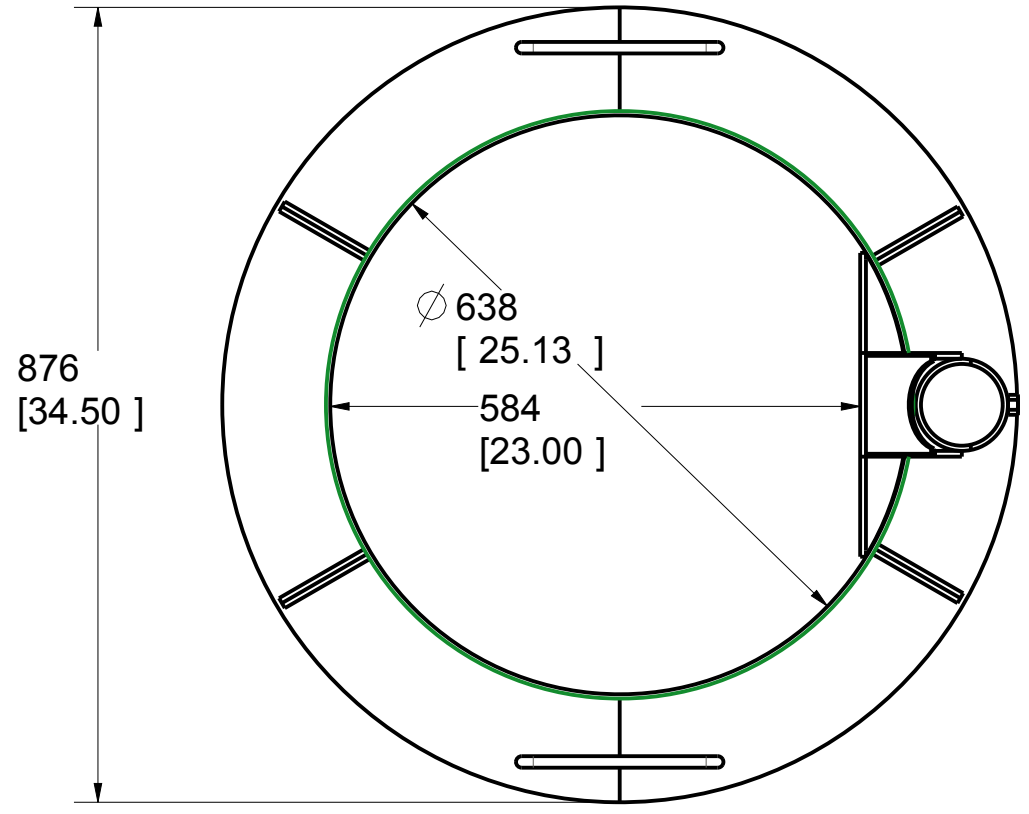

PAT. NO.:		©04/12/2009 ©	
PRODUITS DE SERVICE PUBLICS INNOVA INC. INNOVA PUBLIC UTILITY PRODUCTS INC.			
<small>© 9105-0732 QUEBEC INC. and under exclusive license to INNOVA PUBLIC UTILITY PRODUCTS INC., (hereafter « INNOVA »). All rights reserved. Protected under the Copyright Act of Canada and international treaties and agreements regarding copyrights. Violators are subject to prosecution and other legal recourses for infringement. Any reproduction, adaptation or other use or disclosure whatsoever, in totality or in part, and in any form or by any means whatsoever, strictly forbidden and requires the prior written approval of INNOVA. All data is the exclusive property of 9105-0732 QUEBEC INC. and under exclusive license to INNOVA and cannot be used nor disclosed in any way either without the prior written approval of INNOVA.</small>			
WEIGHT:	TITLE:		
40 Lbs	Manhole entry ring system		
18 Kg	for hole 26" to 28"		
COLOR:	MATERIAL:	SHEET(S):	PROJECT:
Yellow security	Aluminum	1 / 4	SPXTIN2222

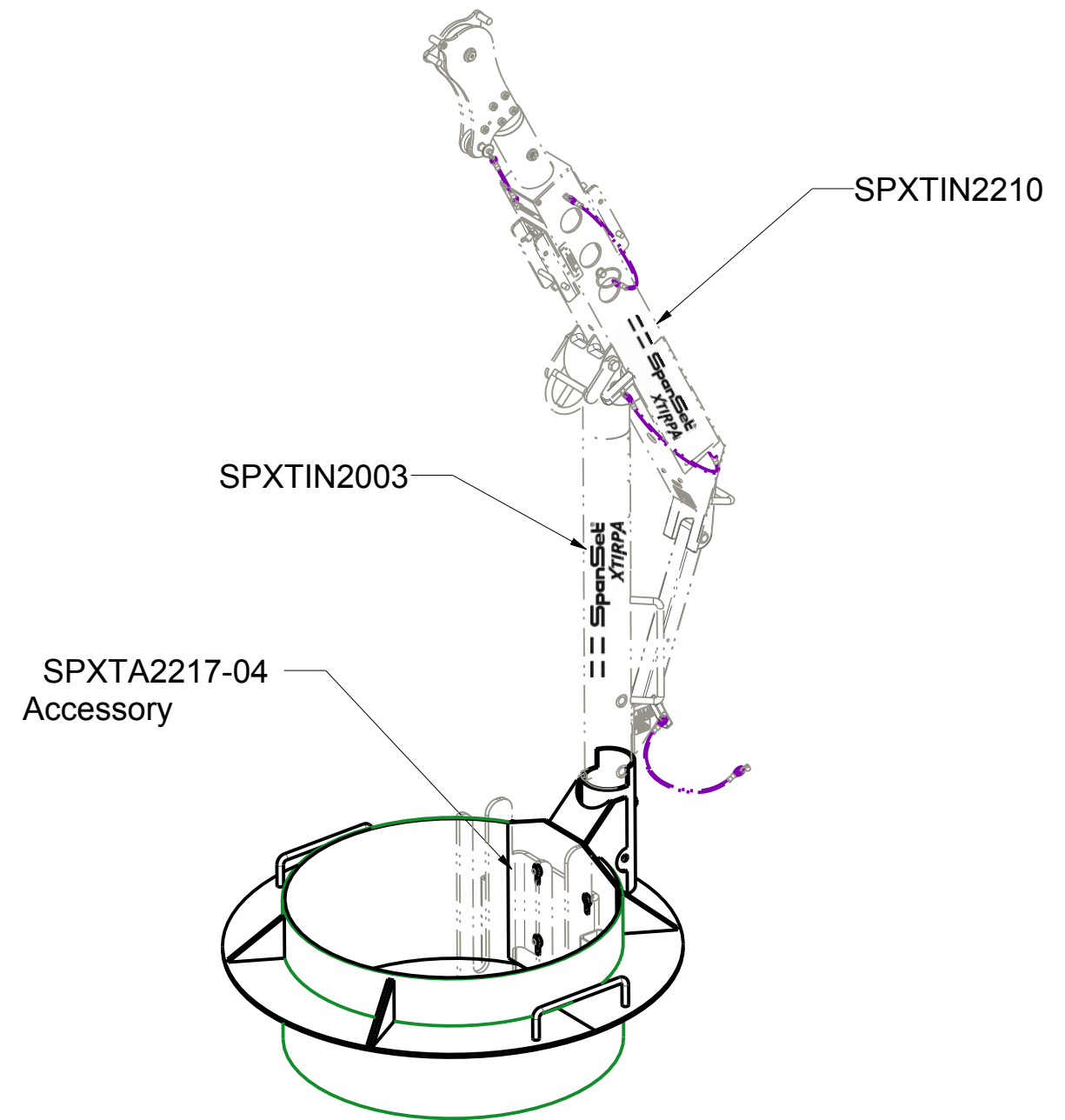
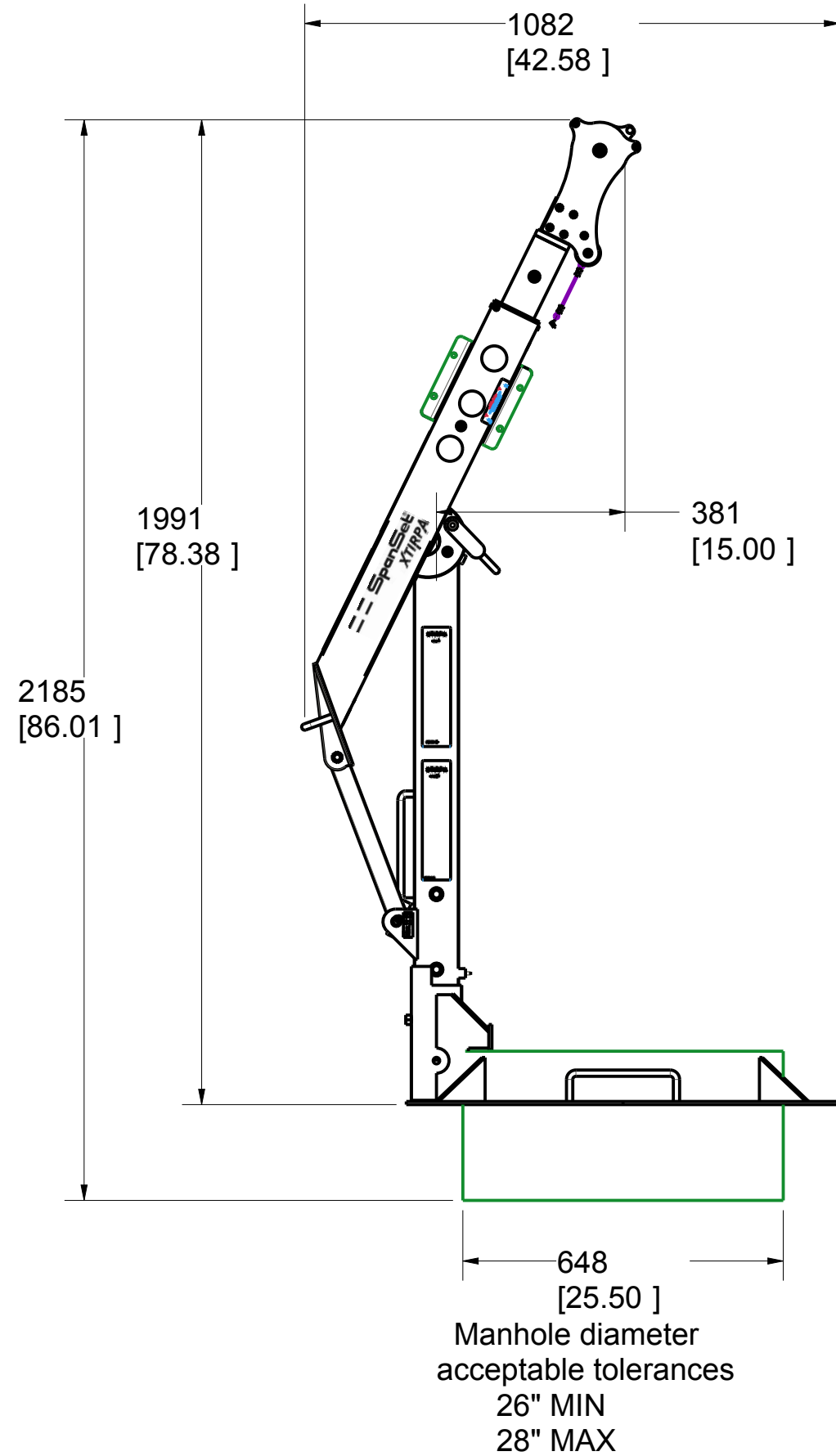

PAT. NO.:		©04/12/2009	©
PRODUITS DE SERVICE PUBLICS INNOVA INC. INNOVA PUBLIC UTILITY PRODUCTS INC.			
<small>© 9105-0732 QUEBEC INC. and under exclusive license to INNOVA PUBLIC UTILITY PRODUCTS INC., (hereafter « INNOVA »). All rights reserved. Protected under the Copyright Act of Canada and international treaties and agreements regarding copyrights. Violators are subject to prosecution and other legal recourses for infringement. Any reproduction, adaptation or other use or disclosure whatsoever, in totality or in part, and in any form or by any means whatsoever, strictly forbidden and requires the prior written approval of INNOVA. All data is the exclusive property of 9105-0732 QUEBEC INC. and under exclusive license to INNOVA and cannot be used nor disclosed in any way either without the prior written approval of INNOVA.</small>			
WEIGHT:	TITLE:		
40 Lbs	Manhole entry ring system		
18 Kg	for hole 26" to 28"		
COLOR:	MATERIAL:	SHEET(S):	PROJECT:
Yellow security	Aluminum	2 / 4	SPXTIN2222

8 7 6 5 4 3 2 1

SPECIFICATIONS

H This product is man rated with a maximum working capacity of 360lbs (164kg). It is only to be used in conjunction with personal fall arrest equipment that limits the maximum arrerst force (MAF).

G Working load (mass) and moment:
With mast SPXTIN2003 and Davit Arm SPXTIN2210 : 164kg (360lbs), 610 N-m (5400 lb-in)

G Max Design Capacity
With mast SPXTIN2003 and Davit Arm SPXTIN2210 : 16014 N (3600 lbf), 6101 N-m (54000 lbf-in)

F **STANDARDS**

F Meets the following standards:
OSHA Personal fall arrest system - 1910.66 App C
ANSI Safety requirements for personal fall arrest system, subsystems and components Z359.1 (R1999)
CAN/CSA Fall arresters, vertical lifelines, and rails Z259.2.1-98

E **MATERIAL AND CONSTRUCTION**

D Rings, Handles, reinforcements and sleeve : Aluminum 6061-T6
Sleeve bearing : PVC
Pin : Zinc plated Steel
Lanyard : Nylon covered Steel Cable
Finish : Yellow security powder paint with metal protection base.
Welding Certification : CSA W47,2M

C **RESTRICTIONS**

C This product is to be used only with products approved by Innova public utility products INC. such as: Davit Arm SPXTIN2210 and Mast SPXTIN2003

B **IMPORTANT :**

B **The positioning pin must always be in place when maneuvering personnel. Otherwise, serious injuries may occur.

A Periodic inspections of hardware must be done.
All equipment and hardware must be inspected before re-using by qualified personnel when a fall has occured.

A ** This equipment must always be operated in a leveled position

Product number: SPXTIN2222

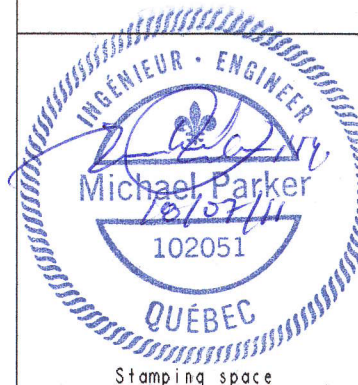
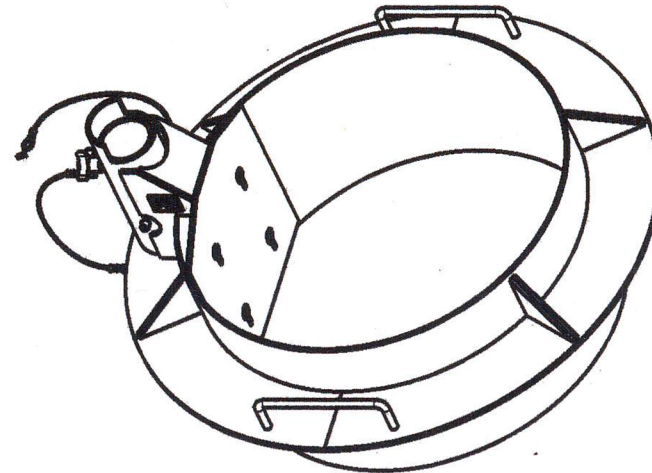

PAT. NO.:		004/12/2009 e	
PRODUITS DE SERVICE PUBLICS INNOVA INC. INNOVA PUBLIC UTILITY PRODUCTS INC.			
<small>© 9105-0732 QUEBEC INC. and under exclusive license to INNOVA PUBLIC UTILITY PRODUCTS INC. (hereafter "INNOVA"). All rights reserved. Protected under the Copyright Act of Canada and international treaties and agreements regarding copyrights. Violators are subject to prosecution and other legal recourse for infringement. Any reproduction, adaptation or other use or disclosure whatsoever, in totality or in part, and in any form or by any means whatsoever, strictly forbidden and requires the prior written approval of INNOVA. All data is the exclusive property of 9105-0732 QUEBEC INC. and under exclusive license to INNOVA and cannot be used nor disclosed in any way either without the prior written approval of INNOVA.</small>			
WEIGHT:	TITLE:		
40 Lbs	Manhole entry ring system		
18 Kg	for hole 26" to 28"		
COLOR:	MATERIAL:	SHEET(S):	PROJECT:
Yellow security	Aluminum	3 / 4	SPXTIN2222

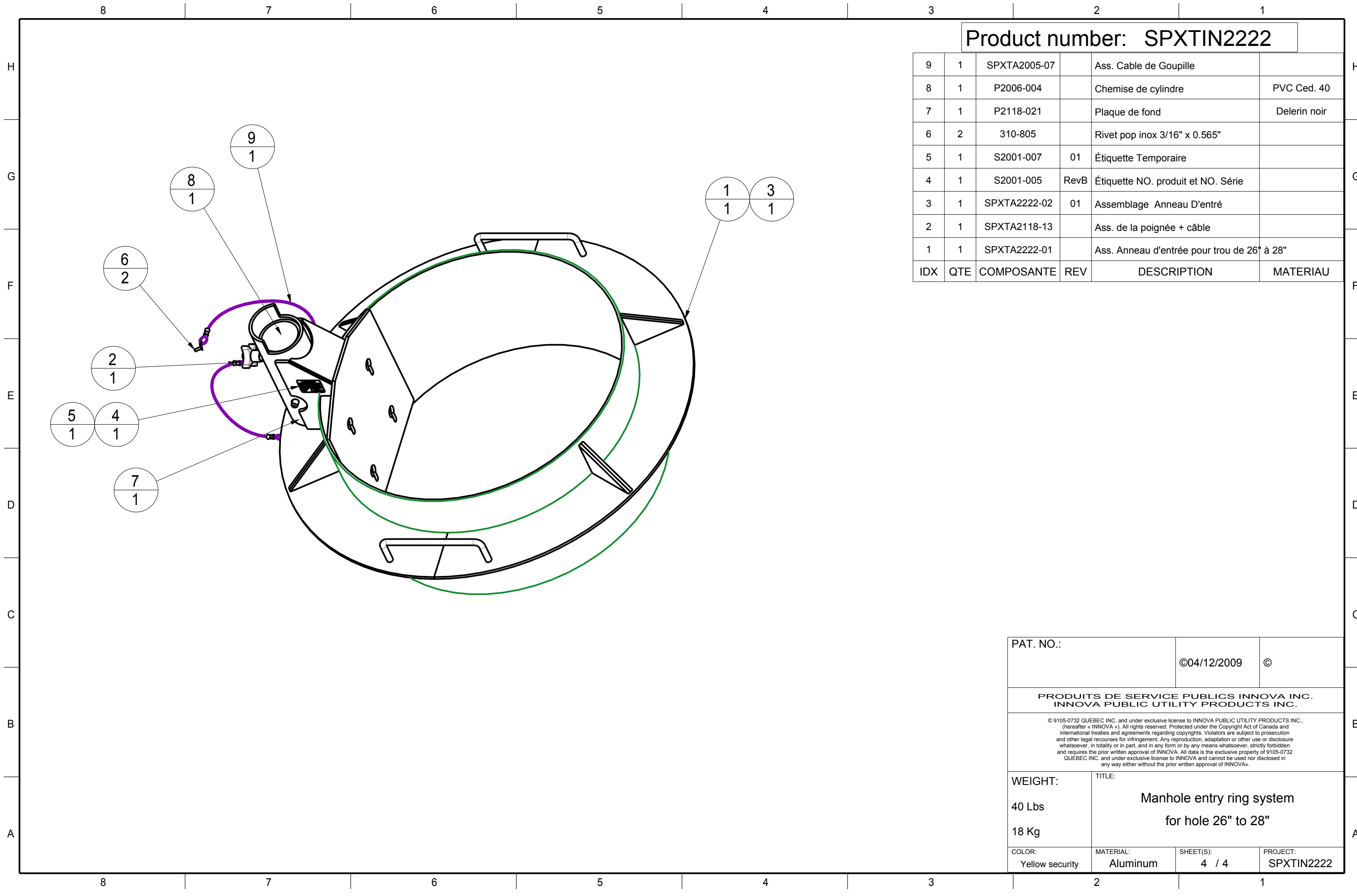

Product number: SPXTIN2222

IDX	QTE	COMPOSANTE	REV	DESCRIPTION	MATERIAU
9	1	SPXTA2005-07		Ass. Cable de Goupille	
8	1	P2006-004		Chemise de cylindre	PVC Ced. 40
7	1	P2118-021		Plaque de fond	Delerin noir
6	2	310-805		Rivet pop inox 3/16" x 0.565"	
5	1	S2001-007	01	Étiquette Temporaire	
4	1	S2001-005	RevB	Étiquette NO. produit et NO. Série	
3	1	SPXTA2222-02	01	Assemblage Anneau D'entrée	
2	1	SPXTA2118-13		Ass. de la poignée + câble	
1	1	SPXTA2222-01		Ass. Anneau d'entrée pour trou de 26" à 28"	

PAT. NO.:		©04/12/2009	©
PRODUITS DE SERVICE PUBLICS INNOVA INC. INNOVA PUBLIC UTILITY PRODUCTS INC.			
© 9105-0732 QUEBEC INC. and under exclusive license to INNOVA PUBLIC UTILITY PRODUCTS INC., (hereafter « INNOVA »). All rights reserved. Protected under the Copyright Act of Canada and international treaties and agreements regarding copyrights. Violators are subject to prosecution and other legal recourses for infringement. Any reproduction, adaptation or other use or disclosure whatsoever, in totality or in part, and in any form or by any means whatsoever, strictly forbidden and requires the prior written approval of INNOVA. All data is the exclusive property of 9105-0732 QUEBEC INC. and under exclusive license to INNOVA and cannot be used nor disclosed in any way either without the prior written approval of INNOVA.			
WEIGHT:	TITLE:		
40 Lbs	Manhole entry ring system for hole 26" to 28"		
18 Kg			
COLOR:	MATERIAL:	SHEET(S):	PROJECT:
Yellow security	Aluminum	4 / 4	SPXTIN2222