



Engineering
Lifting equipment
Technical services

Wind energy

AXZION TAP

Tower attachment point

We satisfy all safety and quality requirements

Time and again, the dangers and liability risks when lifting and moving heavy loads are not given sufficient consideration – sometimes with dramatic consequences for management and affected employees. The selection of an unsuitable manufacturer alone can lead to personal liability of the responsible circle of individuals.

We bear the responsibility for you. You are buying from a company which operates in strict adherence to the norms – starting from proof of suitable welding in accordance with DIN 18800 and DIN 15018 for static and dynamic supporting structures to material inspection test certificate EN 10 204/3.1b through to factory certification, operating instructions and CE declarations.

AXZION wind energy products

600-ton test for lifting devices | Test service

Rotary hoists | Lifting-beam combos | Custom-designed lifting solutions

Roundslings | Reinforced lifting straps | Edge protection for blades

Impact protection | Fall protection systems

Your Axzion plant representation

Axzion GKS Stahl- und Maschinenbau GmbH
Email info@axzion.de | Web www.axzion.de

© AXZION GKS | No copying allowed without permission. All descriptions are drawn up to the best of our knowledge. No guarantee is provided. We reserve the right to make technical changes and improvements.

www.axzion.de



AXZION TAP

TAP

Tower attachment point

High-strength, tried-and-tested attachment points for towers of every diameter



TAP- the new attachment point for tower segments

Higher performance installations, offshore use, ever heavier tower segments for wind turbines. The lifting brackets developed in the past are no longer strong enough; the usual three attachment screws are no longer enough to ensure lifting capacity. Limit plates with four or more single pressure-tap holes must be additionally fitted to each flange, and these heavy construction solutions can only be handled with the aid of a crane.

The Tower Attachment Point (TAP) was redeveloped for tower segments of up to 100 tonnes with the common bolt pitches from 2.5 – 4.2m flange diameter. Each individual TAP bracket has a load capacity of 25 tonnes at a maximum acceptable angle of 30° to the lifting device. The TAP brackets are drop-forged and are made of high-quality heat-treated steel. Because of the high-tensile material the brackets weigh a maximum of 30 kg and two people can easily rig them by hand.

On the load side, a standard high-tensile shackle with a 25 tonne nominal rating can be threaded into the TAP bracket, making the connection to the usual round slings or wire ropes as simple as possible. The securing of the load has also been considered: multiple lashing hooks can be attached to the TAP bracket simultaneously. On the tower side, the Tower Attachment Point, (TAP) is mounted using 2 x 2 screws with an 8.8 rating of sizes M36, M42 to a maximum of M48. Both long holes are slightly curved to match the radius of the tower (patent pending), allowing mounting to almost any tower segment with a diameter between a maximum of 4.2m and a minimum of 2.5m.

As any technician knows, two long holes in the same direction do not work as the fitting could suddenly slip under a full load. This is where the second patent from GKS-Axzion's development group comes into effect: each long hole has two bevels alongside it which run in opposite directions. The screws are attached to these bevels by means of wedge-shaped tapered base plates. Under lateral tension the load on the screw is increased in the direction of the tension, the contact pressure increases and lateral movement becomes impossible.

For turbine-tower segments of up to 100 tonnes
Bolt patterns of 2.5 to 4.2 m
Lifting capacity per TAP: 25 tonnes
Dead weight: 30 kg

Lateral tension increases the contact pressure.

Sideways slipping is no longer an issue.



Safety is a priority for us.

AXZION-GKS is the specialist for lifting devices in the global SpanSet Group. Safety is naturally very important. On our test stand, the forged TAP brackets were tested to 125 tonnes, five times their rated load capacity. The requirements of EN 13155 "Lifting Devices" are therefore exceeded. This proven 5:1 safety factor even permits use in the United States. In addition to the brackets mounting with screws from M36, 8.8 has also been fully tested.

We seek a partnership with a major manufacturer of wind turbines. Further tests are underway, increasing the rated load of the TAP bracket to 35 tonnes at SF 1:5, in the future the high-tensile fittings will be used in the erection of the tower segments.

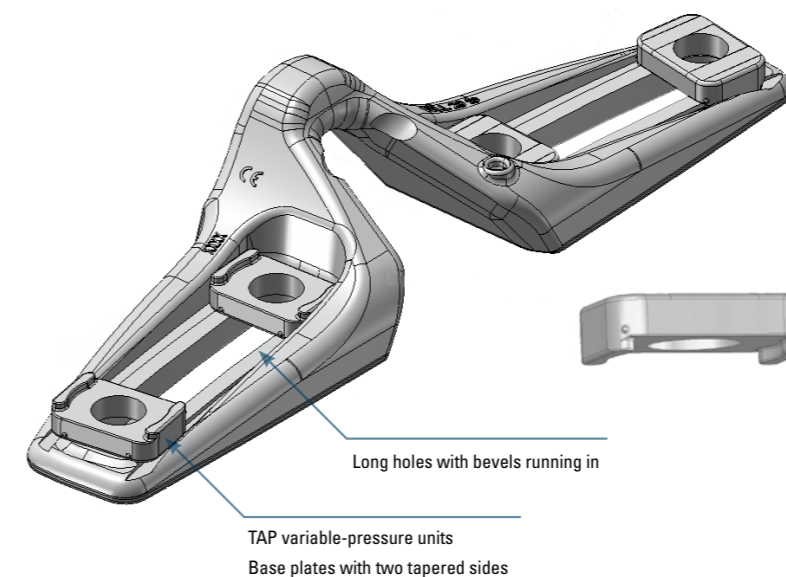

AXZION TAP

TAP

Tower attachment point

High-strength, tried-and-tested attachment points for towers of every diameter

Quality, tried and tested:
5x nominal rating (125 tonnes)

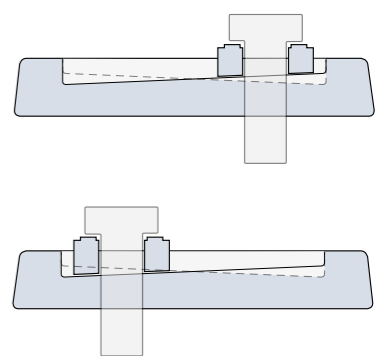

Lateral tension increases the contact pressure.

Sideways slipping is no longer an issue.